

THESE DRAWINGS ARE SUGGESTED
INSTALLATION DETAILS ONLY;
ALL ATTACHMENTS, STEEL SIZES,
GAUGE THICKNESS, AND ANCHOR
SIZES SHOULD BE CALCULATED
BY A STRUCTURAL ENGINEER;
WE ARE NOT LIABLE FOR
INSTALLATION OF ANY KIND

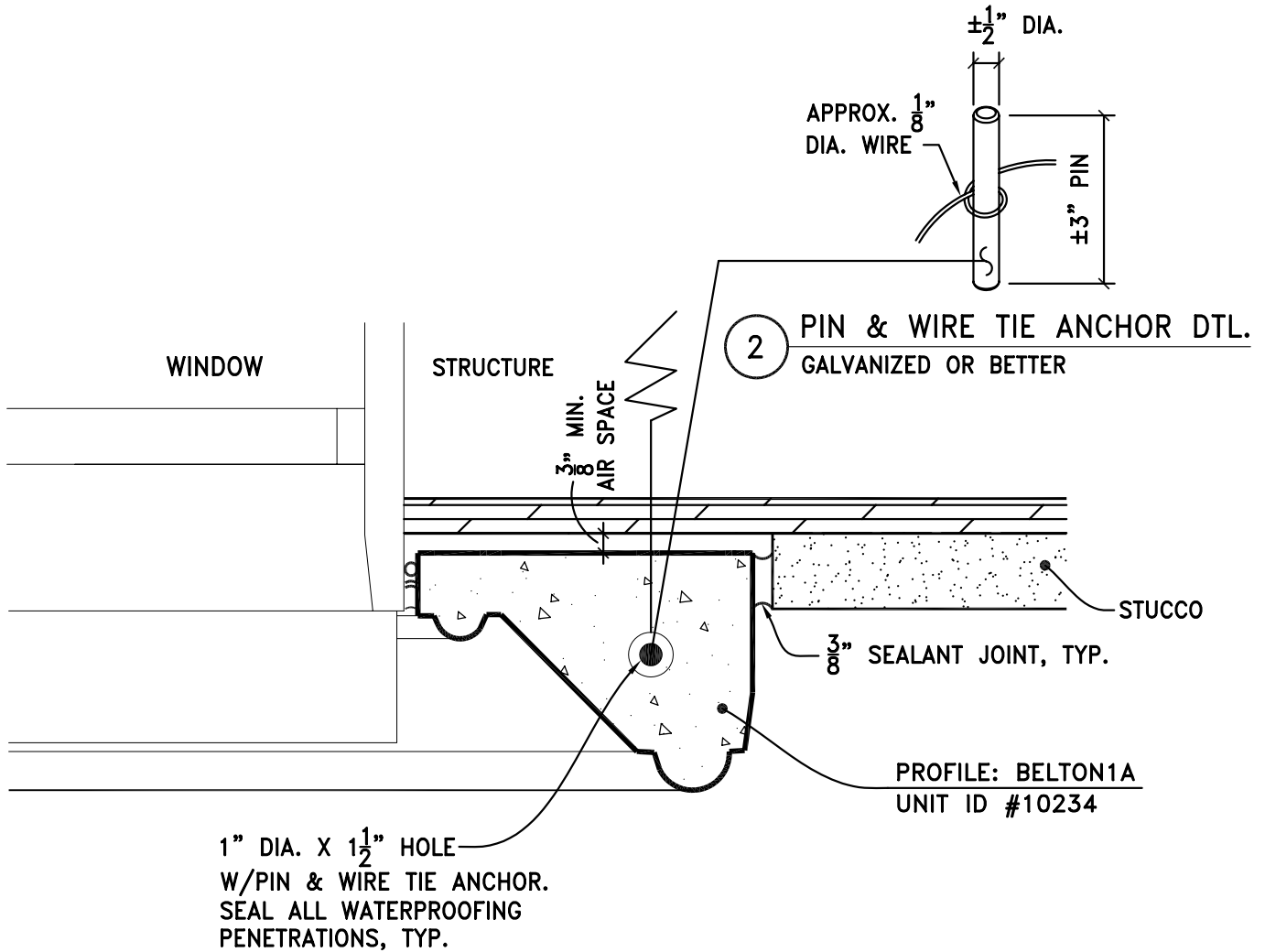

1 CAST STONE JAMB ATTACHMENT AT STUCCO
WITH PIN & WIRE TIE ANCHOR

TYPICAL USES:
WINDOW & DOOR LEG

STD 3/8" MORTAR JOINT

SCALE: N.T.S.

STONE LEGENDS

301 Pleasant Drive - Dallas, TX 75217
Voice (214) 398-0999 - Fax (214) 398-1293
Visit our website at www.stonelegends.com

CLIENT:
PROJECT: